

UD info Corp.

Industrial SD Card
SDC-09UD Series
Product DataSheet

UD info CORP.

3F-4, No.8, Ln. 609, Sec. 5, Chongxin Rd., Sanchong Dist., New Taipei City 241, Taiwan (R.O.C.)

TEL: +886-2-7713-6050 FAX: +886-2-8511-3151

E-mail: sales@UDinfo.com.tw

1.	Introduction	5
1.1.	General Description	5
2.	Product Specifications	6
3.	Environmental Specifications	8
3.1.	Environmental Conditions	8
3.2.	MTBF.....	12
3.3.	Certification	12
4.	SD Card Comparison	13
5.	Electrical Specifications	14
5.1.	Power Consumption.....	14
5.2.	DC Characteristic.....	14
5.2.1.	Bus Operation Conditions for 3.3V Signaling	14
5.2.2.	Bus Signal Line Load.....	15
5.2.3.	Power Up Time	16
5.3.	AC Characteristic.....	17
5.3.1.	SD Interface Timing (Default)	18
5.3.2.	SD Interface Timing (High-Speed Mode).....	19
5.3.3.	SD Interface Timing (SDR12, SDR25 and SDR50 Modes)	20
5.3.4.	SD Interface Timing (DDR50 Mode)	21
6.	Interface	23
6.1.	Pad Assignment and Descriptions.....	23
7.	Physical Dimension	25
8.	Barcode description	26
9.	Partnumber decoder	26

Revision History

Revision	Draft Date	History	Author
1.0	2014/5/26	New release	Golden Lee



Product Overview

- **Capacity**
 - SLC: 128MB up to 32GB
 - pSLC: 2GB up to 32GB
 - MLC: 4GB up to 64GB
- **Flash Type**
 - Flash Type: SLC, MLC, and pSLC
- **Bus Speed Mode**
 - 128MB to 2GB: Non-UHS
 - 4GB to 64GB: UHS-I
- **Performance**
 - Read: up to 27 MB/s
 - Write: up to 25 MB/s
- **Power Consumption**^{Note1}
 - Power Up Current < 250uA
 - Standby Current < 250uA
 - Read Current < 200mA
 - Write Current < 200mA
- **MTBF**
 - More than 3,000,000 hours
- **Advanced Flash Management**
 - Static and Dynamic Wear Leveling
 - Bad Block Management
 - SMART Function
 - Auto-Read Refresh
- **Temperature Range**
 - Operation (Standard): -25°C ~ 85°C
 - Operation (Wide): -40°C ~ 85°C
 - Storage: -40°C ~ 85°C
- **Compliant**
 - RoHS
 - CE & FCC

Notes:

1. Please see "Power Consumption" for details.

1. INTRODUCTION



1.1. General Description

The Secure Digital (SD) card version 3.0 is fully compliant with the specification released by SD Card Association. The Command List supports [Part 1 Physical Layer Specification Ver3.01 Final] definitions. Card capacities of non-secure area and secure area support [Part 3 Security Specification Ver3.0 Final] Specifications.

The SD 3.0 card is based on 9-pin interface, designed to operate at a maximum operating frequency of 100MHz. It can alternate communication protocol between the SD mode and SPI mode. It performs data error detection and correction with very low power consumption. The Card capacity could be more than 64GB and up to 2TB in the future with ex-FAT which is called SDXC (Extended Capacity SD Memory Card).

Secure Digital 3.0 card is one of the most popular cards today based on its high performance, good reliability and wide compatibility. Not to mention that it's well adapted for hand-held applications in semi-industrial/medical markets already.

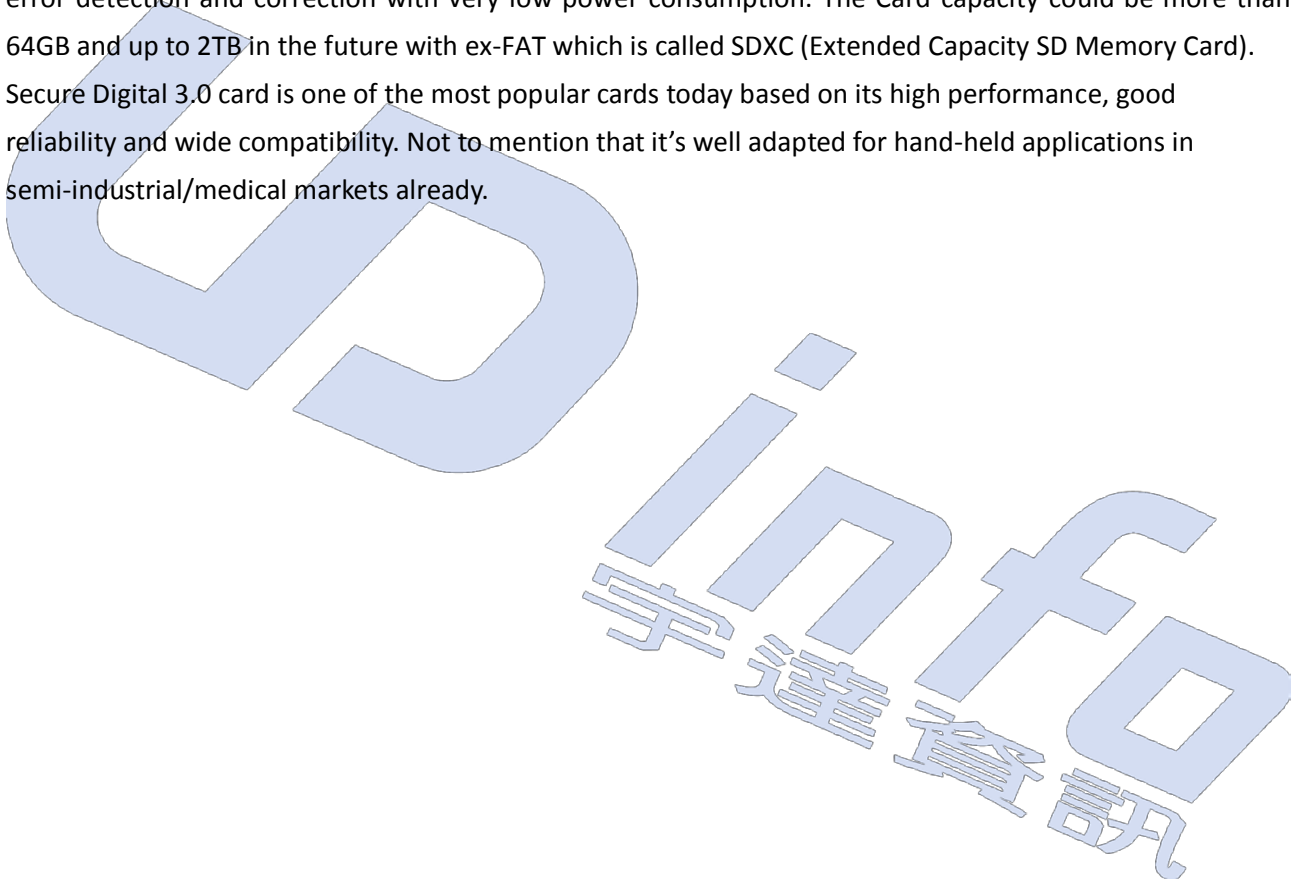

2. PRODUCT SPECIFICATIONS



- **Capacity**
 - SLC: 128MB up to 32GB
 - MLC: 4GB up to 64GB
 - pSLC: 2GB up to 32GB
- **Operation Temp. Range**
 - Operation (Standard): -25°C ~ 85°C
 - Operation (Wide): -40°C ~ 85°C
 - Storage: -40°C ~ 85°C
- **Support SD system specification version 3.0**
- **Card capacity of non-secure area and secure area support [Part 3 Security Specification Ver3.0 Final] Specifications**
- **Support SD SPI mode**
- **Designed for read-only and read/write cards**
- **Bus Speed Mode (use 4 parallel data lines)**
 - **Non-UHS mode**
 - Default speed mode: 3.3V signaling, frequency up to 25MHz, up to 12.5 MB/sec
 - High speed mode: 3.3V signaling, frequency up to 50MHz, up to 25 MB/sec

Note: SDSC card (capacity less than and including 2GB) only supports non-UHS mode.
 - **UHS-I mode**
 - SDR12: SDR up to 25MHz, 1.8V signaling
 - SDR25: SDR up to 50MHz, 1.8V signaling
 - SDR50: 1.8V signaling, frequency up to 100MHz, up to 50 MB/sec
 - DDR50: 1.8V signaling, frequency up to 50MHz, sampled on both clock edges, up to 50 MB/sec

Note: Timing in 1.8V signaling is different from that of 3.3V signaling.
- **The command list supports [Part 1 Physical Layer Specification Ver3.1 Final] definitions**
- **Copyrights Protection Mechanism**
 - Compliant with the highest security of SDMI standard
- **Support CPRM (Content Protection for Recordable Media) of SD Card**
- **Card removal during read operation will never harm the content**

UD info CORP. TEL: +886-2-7713-6050 FAX: +86-2-8511-3151

3F-4, No.8, Ln. 609, Sec. 5, Chongxin Rd., Sanchong Dist., New Taipei City 241, Taiwan (R.O.C.)

- Password Protection of cards (optional)
- Write Protect feature using mechanical switch
- Built-in write protection features (permanent and temporary)
- +4KV/-4KV ESD protection in contact pads
- Operation voltage range: 2.7 ~ 3.6V



3. ENVIRONMENTAL SPECIFICATIONS



3.1. Environmental Conditions

Temperature and Humidity

- Storage Temperature Range
 - -40°C ~ 85°C
- Operation Temperature Range
 - Standard Temperature: -25°C ~ 85°C
 - Wide Temperature: -40°C ~ 85°C

Table 3-1 High Temperature Test Condition (Standard)

	Temperature	Humidity	Test Time
Operation	85°C	0% RH	168 hours
Storage	85°C	0% RH	500 hours

Result: No any abnormality is detected.

Table 3-2 High Temperature Test Condition (Wide)

	Temperature	Humidity	Test Time
Operation	85°C	0% RH	300 hours
Storage	85°C	0% RH	500 hours

Result: No any abnormality is detected.

Table 3-3 Low Temperature Test Condition (Standard)

	Temperature	Humidity	Test Time
Operation	-25°C	0% RH	168 hours
Storage	-40°C	0% RH	300 hours

Result: No any abnormality is detected.

Table 3-4 Low Temperature Test Condition (Wide)

	Temperature	Humidity	Test Time
Operation	-40°C	0% RH	168 hours
Storage	-40°C	0% RH	500 hours

Result: No any abnormality is detected.

Table 3-5 High Humidity Test Condition

	Temperature	Humidity	Test Time
Operation	40°C	95% RH	4 hours
Storage	40°C	95% RH	500 hours

Result: No any abnormality is detected.

Table 3-6 High Humidity Test Condition

	Temperature	Humidity	Test Time
Operation	55°C	95% RH	4 hours
Storage	55°C	95% RH	500 hours

Result: No any abnormality is detected.

Table 3-7 Temperature Cycle Test (Standard)

	Temperature	Test Time	Cycle
Operation	-25°C	30 min	20 Cycles
	85°C	30 min	
Storage	-40°C	30 min	20 Cycles
	85°C	30 min	

Result: No any abnormality is detected.

Table 3-8 Temperature Cycle Test (Wide)

	Temperature	Test Time	Cycle
Operation	-40°C	30 min	20 Cycles
	85°C	30 min	
Storage	-40°C	30 min	50 Cycles
	85°C	30 min	

Result: No any abnormality is detected.

Shock

Table 3-9 Shock Specification

	Acceleration Force	Half Sin Pulse Duration
Industrial SD card	1500G	0.5ms

Result: No any abnormality is detected when power on.

Vibration

Table 3-10 Vibration Specification

	Condition		Vibration Orientation
	Frequency/Displacement	Frequency/Acceleration	
Industrial SD card	20Hz~80Hz/1.52mm	80Hz~2000Hz/20G	X, Y, Z axis/30 min for each

Result: No any abnormality is detected when power on.

Drop

Table 3-11 Drop Specification

	Height of Drop	Number of Drop
Industrial SD card	150cm free fall	6 face of each unit

Result: No any abnormality is detected when power on.

Bending

Table 3-12 Bending Specification

	Force	Action
Industrial SD card	≥ 10N	Hold 1min/5times

Result: No any abnormality is detected when power on.

Torque

Table 3-13 Torque Specification

	Force	Action
Industrial SD card	0.15N-m or +/-2.5 deg	Hold 30 seconds/5times

Result: No any abnormality is detected when power on.

Salt Spray Test

Table 3-14 Salt Spray Test

	Temperature	Concentration	Duration
Industrial SD card	35°C	3% NaCl	Storage for 24 hours

Result: No any abnormality is detected when power on.

Waterproof Test (only applies to SIP type)

Table 3-15 Waterproof Test

	Water Depth	Duration
Industrial SD card	1000mm	Submerge for 30 minutes

Result: JIS IPX7 compliance. No any abnormality is detected when power on

X-Ray Exposure Test

Table 3-16 X-Ray Exposure Test

	Condition	Duration
Industrial SD card	0.1 Gy of medium energy radiation (70 keV to 140keV, cumulative does per year) to both sides of the card.	Storage for 30mins

Result: ISO 7816-1 compliance. No any abnormality is detected when power on

Switch Cycle Test

Table 3-17 Switch Cycle Test

	Applied Force	Result
Industrial SD card	0.4~0.5 N 1000 times	PASS

Result: No any abnormality is detected when power on

Durability Test

Table 3-18 Durability Test

	Mating cycle	Result
Industrial SD card	10000 times	PASS

Result: No any abnormality is detected when power on

Electrostatic Discharge (ESD)

Table 3-19 Contact ESD Specification

	Condition	Result
Industrial SD card	Contact: +/- 4KV each item 25 times Air: +/- 15KV 10 times	PASS

3.2. MTBF

MTBF, an acronym for Mean Time Between Failures, is a measure of a device's reliability. Its value represents the average time between a repair and the next failure. The measure is typically in units of hours. The higher the MTBF value, the higher the reliability of the device. The predicted result of UDinfo's SD is more than 3,000,000 hours.

3.3. Certification

- RoHS
- CE / FCC



4. SD CARD COMPARISON



Table 4-1 Comparing SD3.0 Standard / SD3.0 SDHC / SD3.0 SDXC

	SD3.0 Standard (Backward compatible to 2.0 host)	SD3.0 SDHC (Backward compatible to 2.0 host)	SD3.0 SDXC
Addressing Mode	Byte (1 byte unit)	Block (512 byte unit)	Block (512 byte unit)
HCS/CCS bits of ACMD41	Support	Support	Support
CMD8 (SEND_IF_COND)	Support	Support	Support
CMD16 (SET_BLOCKLEN)	Support	Support (Only CMD42)	Support (Only CMD42)
Partial Read	Support	Not Support	Not Support
Lock/Unlock Function	Mandatory	Mandatory	Mandatory
Write Protect Groups	Optional	Not Support	Not Support
Supply Voltage 2.0v – 2.7v (for initialization)	Not Support	Not Support	Not Support
Total Bus Capacitance for each signal line	40pF	40pF	40pF
CSD Version (CSD_STRUCTURE Value)	1.0 (0x0)	2.0 (0x1)	2.0 (0x1)
Speed Class	Optional	Mandatory (Class 2 / 4 / 6 / 10)	Mandatory (Class 2 / 4 / 6 / 10)

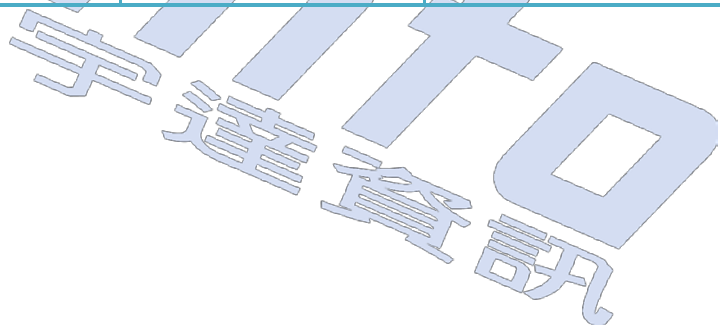

5. ELECTRICAL SPECIFICATIONS



5.1. Power Consumption

The table below is the power consumption of SD card with different flash memory types.

Table 5-1 Power Consumption of Industrial SD card

Flash Mode	Max. Power Up Current (uA)	Max. Standby Current (uA)	Max. Read Current (mA)	Max. Write Current (mA)
Single Flash ^{Note1} (1 x 8bit)	150	150	100	100
SDR/DDR	250	250	200	200

Note:

1. Data transfer mode is single channel.

5.2. DC Characteristic

5.2.1. Bus Operation Conditions for 3.3V Signaling

Table 5-2 Threshold Level for High Voltage Range

Parameter	Symbol	Min.	Max	Unit	Condition
Supply Voltage	VDD	2.7	3.6	V	
Output High Voltage	VOH	0.75*VDD		V	IOH=-2mA VDD Min
Output Low Voltage	VOL		0.125*VDD	V	IOL=2mA VDD Min
Input High Voltage	VIH	0.625*VDD	VDD+0.3	V	
Input Low Voltage	VIL	VSS-0.3	0.25*VDD	V	
Power Up Time			250	ms	From 0V to VDD min

Table 5-3 Peak Voltage and Leakage Current

Parameter	Symbol	Min	Max.	Unit	Remarks
Peak voltage on all lines		-0.3	V _{DD} +0.3	V	
All Inputs					
Input Leakage Current		-10	10	uA	
All Outputs					
Output Leakage Current		-10	10	uA	

Table 5-4 Threshold Level for 1.8V Signaling

Parameter	Symbol	Min.	Max	Unit	Condition
Supply Voltage	VDD	2.7	3.6	V	
Regulator Voltage	VDDIO	1.7	1.95	V	Generated by VDD
Output High Voltage	VOH	1.4	-	V	IOH=-2mA
Output Low Voltage	VOL	-	0.45	V	IOL=2mA
Input High Voltage	VIH	1.27	2.00	V	
Input Low Voltage	VIL	Vss-0.3	0.58	V	

Table 5-5 Input Leakage Current for 1.8V Signaling

Parameter	Symbol	Min	Max.	Unit	Remarks
Input Leakage Current		-2	2	uA	DAT3 pull-up is disconnected.

5.2.2. Bus Signal Line Load

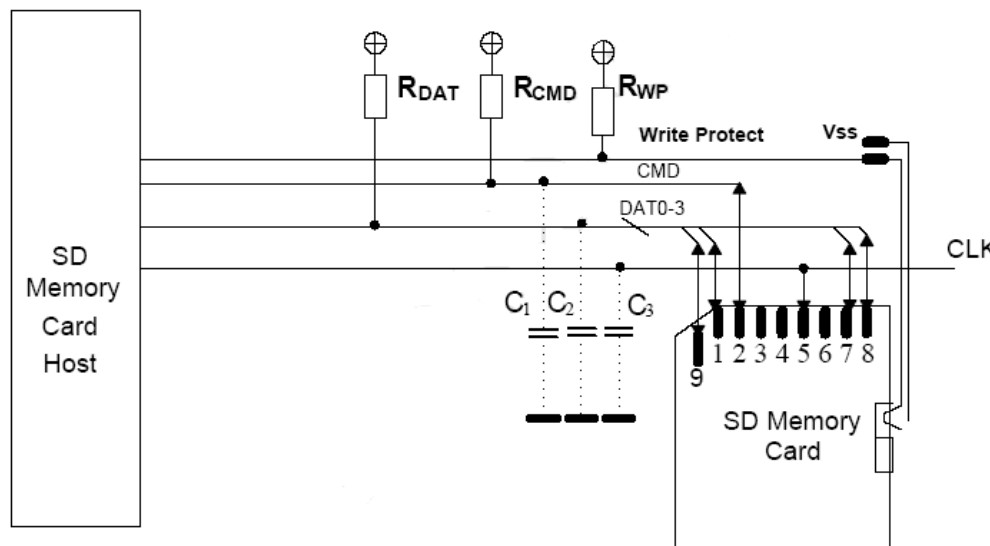

Figure 5-1 Bus Circuitry Diagram

Bus Operation Conditions – Signal Line’s Load

Total Bus Capacitance = $CHOST + CBUS + N \cdot CCARD$

Parameter	symbol	Min	Max	Unit	Remark
Pull-up resistance	R_{CMD} R_{DAT}	10	100	k Ω	to prevent bus floating
Total bus capacitance for each signal line	C_L		40	pF	1 card CHOST+CBUS shall not exceed 30 pF
Card Capacitance for each signal pin	CCARD		10	pF	
Maximum signal line inductance			16	nH	
Pull-up resistance inside card (pin1)	RDAT3	10	90	k Ω	May be used for card detection
Capacity Connected to Power Line	CC		5	μ F	To prevent inrush current

5.2.3. Power Up Time

Host needs to keep power line level less than 0.5V and more than 1ms before power ramp up.

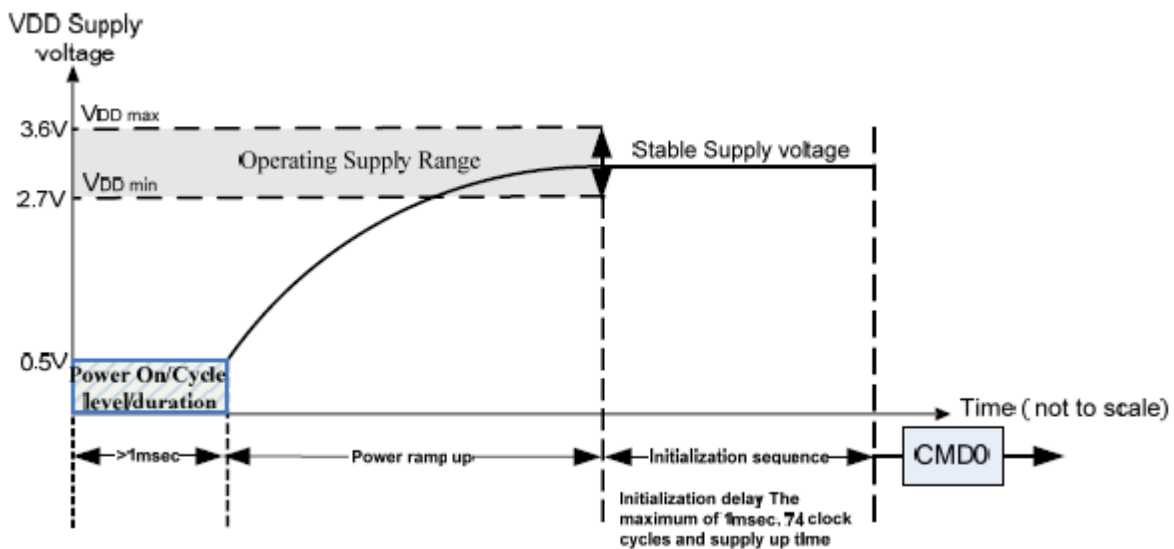

Power On or Power Cycle

Followings are requirements for Power on and Power cycle to assure a reliable SD Card hard reset.

- (1) Voltage level shall be below 0.5V.
- (2) Duration shall be at least 1ms.

Power Supply Ramp Up

The power ramp up time is defined from 0.5V threshold level up to the operating supply voltage which is

UD info CORP. TEL: +886-2-7713-6050 FAX: +86-2-8511-3151
 3F-4, No.8, Ln. 609, Sec. 5, Chongxin Rd., Sanchong Dist., New Taipei City 241, Taiwan (R.O.C.)

stable between VDD (min.) and VDD (max.) and host can supply SDCLK.

Followings are recommendations of Power ramp up:

- (1) Voltage of power ramp up should be monotonic as much as possible.
- (2) The minimum ramp up time should be 0.1ms.
- (3) The maximum ramp up time should be 35ms for 2.7-3.6V power supply.

Power Down and Power Cycle

- (1) When the host shuts down the power, the card VDD shall be lowered to less than 0.5Volt for a minimum period of 1ms. During power down, DAT, CMD, and CLK should be disconnected or driven to logical 0 by the host to avoid a situation that the operating current is drawn through the signal lines.
- (2) If the host needs to change the operating voltage, a power cycle is required. Power cycle means the power is turned off and supplied again. Power cycle is also needed for accessing cards that are already in *Inactive State*. To create a power cycle the host shall follow the power down description before power up the card (i.e. the card VDD shall be once lowered to less than 0.5Volt for a minimum period of 1ms).

5.3. AC Characteristic

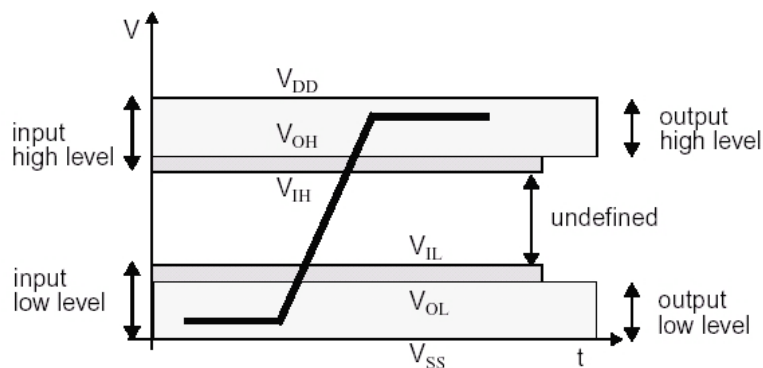

5.3.1. SD Interface Timing (Default)

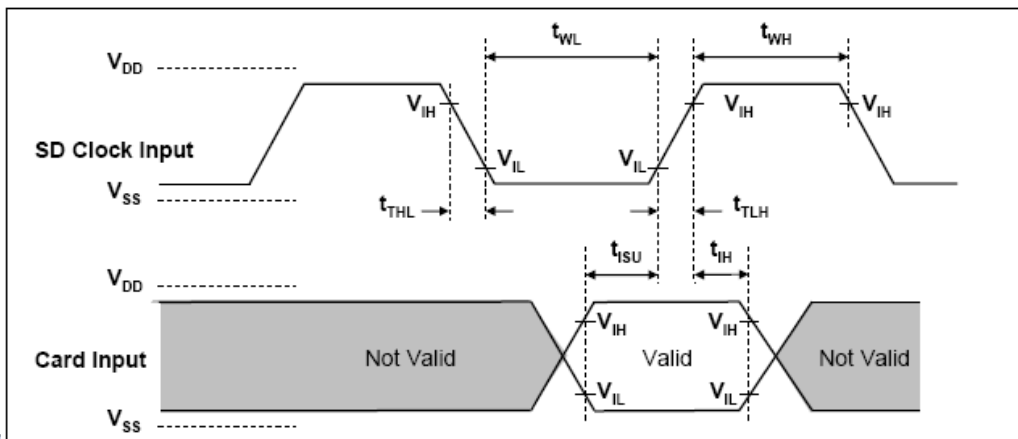

Card Input Timing (Default Speed Card)

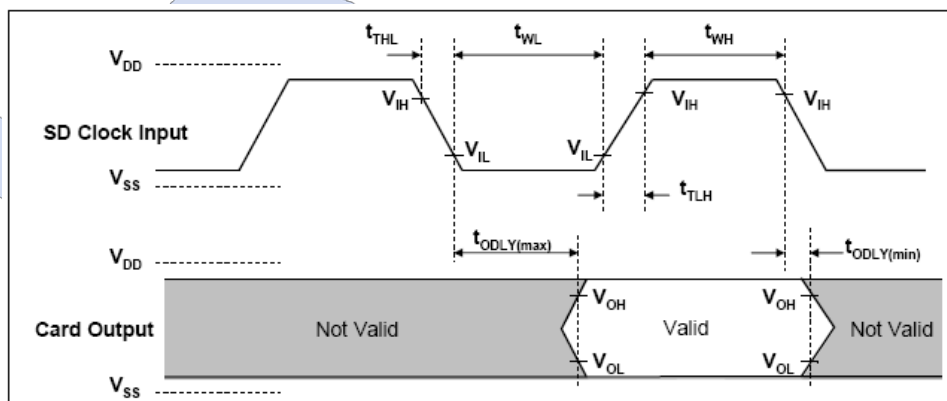

Card Output Timing (Default Speed Mode)

Parameter	Symbol	Min	Max	Unit	Remark
Clock CLK (All values are referred to min(V_{IH}) and max(V_{IL}))					
Clock frequency Data Transfer Mode	f _{pp}	0	25	MHz	C _{card} ≤ □ 10 pF (1 card)
Clock frequency Identification Mode	f _{OD}	0(1)/100	400	kHz	C _{card} ≤ □ 10 pF (1 card)
Clock low time	t _{WL}	10		ns	C _{card} ≤ □ 10 pF (1 card)
Clock high time	t _{WH}	10		ns	C _{card} ≤ □ 10 pF (1 card)
Clock rise time	t _{TLH}		10	ns	C _{card} ≤ □ 10 pF (1 card)
Clock fall time	t _{THL}		10	ns	C _{card} ≤ □ 10 pF (1 card)
Inputs CMD, DAT (referenced to CLK)					
Input set-up time	t _{ISU}	5		ns	C _{card} ≤ □ 10 pF (1 card)
Input hold time	t _{IH}	5		ns	C _{card} ≤ □ 10 pF

UD info CORP. TEL: +886-2-7713-6050 FAX: +86-2-8511-3151

3F-4, No.8, Ln. 609, Sec. 5, Chongxin Rd., Sanchong Dist., New Taipei City 241, Taiwan (R.O.C.)

					(1 card)
Outputs CMD, DAT (referenced to CLK)					
Output Delay time during Data Transfer Mode	t_{ODLY}	0	14	ns	$C_L \leq 40$ pF (1 card)
Output Delay time during Identification Mode	t_{ODLY}	0	50	ns	$C_L \leq 40$ pF (1 card)

(1) 0Hz means to stop the clock. The given minimum frequency range is for cases where continuous clock is required.

5.3.2. SD Interface Timing (High-Speed Mode)

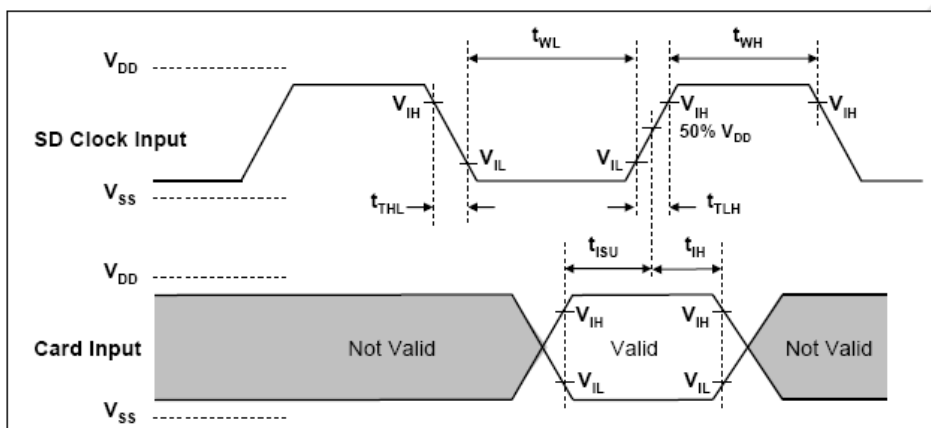

Card Input Timing (High Speed Card)

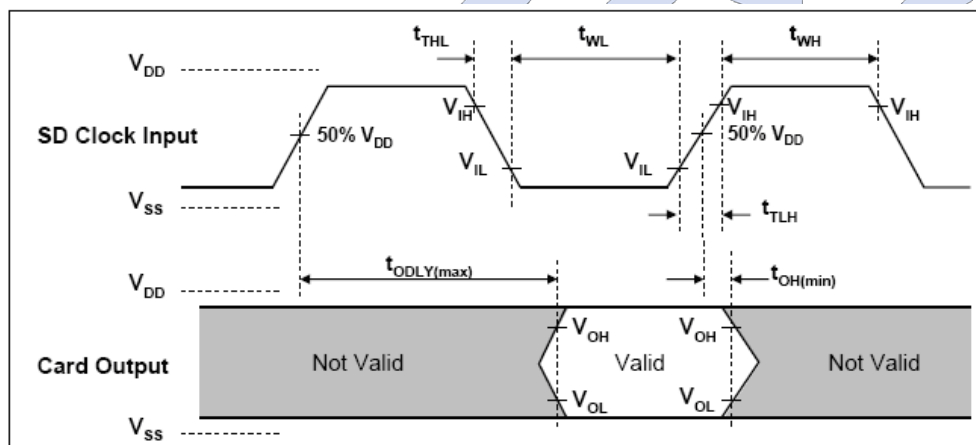

Card Output Timing (High Speed Mode)

Parameter	Symbol	Min	Max	Unit	Remark
Clock CLK (All values are referred to min(V_{IH}) and max(V_{IL}))					
Clock frequency Data Transfer Mode	f_{pp}	0	50	MHz	$C_{card} \leq 10$ pF (1 card)
Clock low time	t_{WL}	7		ns	$C_{card} \leq 10$ pF (1 card)

Clock high time	t_{WH}	7		ns	$C_{card} \leq 10 \text{ pF}$ (1 card)
Clock rise time	t_{TLH}		3	ns	$C_{card} \leq 10 \text{ pF}$ (1 card)
Clock fall time	t_{THL}		3	ns	$C_{card} \leq 10 \text{ pF}$ (1 card)
Inputs CMD, DAT (referenced to CLK)					
Input set-up time	t_{ISU}	6		ns	$C_{card} \leq 10 \text{ pF}$ (1 card)
Input hold time	t_{IH}	2		ns	$C_{card} \leq 10 \text{ pF}$ (1 card)
Outputs CMD, DAT (referenced to CLK)					
Output Delay time during Data Transfer Mode	t_{ODLY}		14	ns	$C_L \leq 40 \text{ pF}$ (1 card)
Output Hold time	T_{OH}	2.5		ns	$C_L \leq 15 \text{ pF}$ (1 card)
Total System capacitance of each line ¹	C_L		40	pF	$CL \leq 15 \text{ pF}$ (1 card)

(1) In order to satisfy severe timing, the host shall drive only one card.

5.3.3. SD Interface Timing (SDR12, SDR25 and SDR50 Modes)

Input

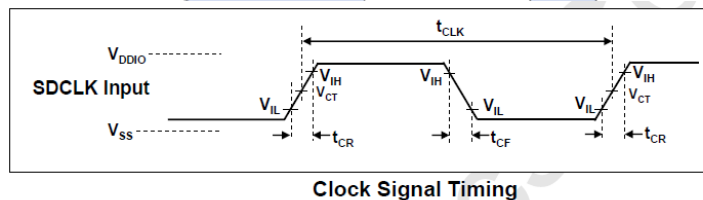
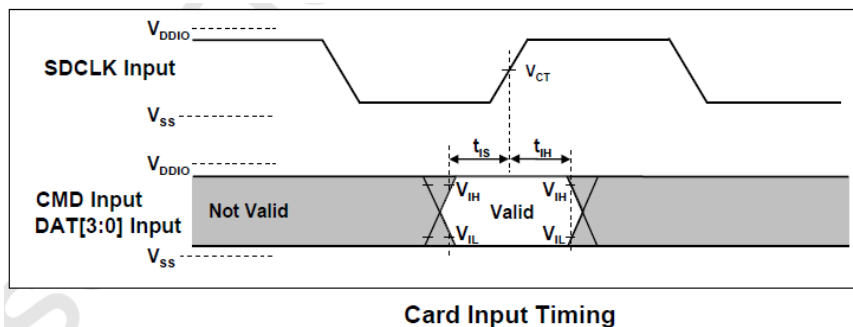

Table 5-6 Clock Signal Timing

Symbol	Min	Max	Unit	Remark
tCLK	4.80	-	ns	208MHz (Max.), Between rising edge, $V_{CT} = 0.975V$
tCR, tCF	-	$0.2 * t_{CLK}$	ns	$t_{CR}, t_{CF} < 2.00ns$ (max.) at 100MHz, $CCARD = 10pF$
Clock Duty	30	70	%	

SDR50 Input Timing



Symbol	Min	Max	Unit	SDR50 Mode
tls	3.00	-	ns	CCARD =10pF, VCT= 0.975V
tIH	0.80	-	ns	CCARD =5pF, VCT= 0.975V

Output

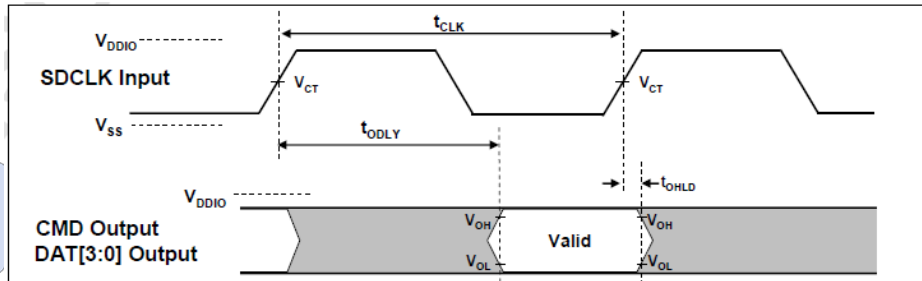

Output Timing of Fixed Data Window

Table 5-7 Output Timing of Fixed Data Window

Symbol	Min	Max	Unit	Remark
tODLY	-	7.5	ns	tCLK>=10.0ns, CL=30pF, using driver Type B, for SDR50
tODLY	-	14	ns	tCLK>=20.0ns, CL=40pF, using driver Type B, for SDR25 and SDR12,
TOH	1.5	-	ns	Hold time at the tODLY (min.), CL=15pF

5.3.4. SD Interface Timing (DDR50 Mode)

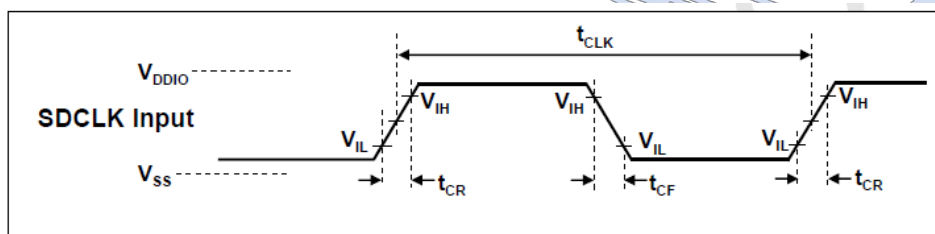

Clock Signal Timing

Symbol	Min	Max	Unit	Remark
tCLK	20	-	ns	50MHz (Max.), Between rising edge
tCR, tCF	-	0.2* tCLK	ns	tCR, tCF < 4.00ns (max.) at 50MHz, CCARD=10pF
Clock Duty	45	55	%	

Table 5-8 Bus Timings – Parameters Values (DDR50 Mode)

Parameter	Symbol	Min	Max	Unit	Remark
Input CMD (referenced to CLK rising edge)					
Input set-up time	t_{ISU}	6	-	ns	$C_{card} \leq 10$ pF (1 card)
Input hold time	t_{IH}	0.8	-	ns	$C_{card} \leq 10$ pF (1 card)
Output CMD (referenced to CLK rising edge)					
Output Delay time during Data Transfer Mode	t_{ODLY}		13.7	ns	$C_L \leq 30$ pF (1 card)
Output Hold time	T_{OH}	1.5	-	ns	$C_L \geq 15$ pF (1 card)
Inputs DAT (referenced to CLK rising and falling edges)					
Input set-up time	t_{ISU2x}	3	-	ns	$C_{card} \leq 10$ pF (1 card)
Input hold time	t_{IH2x}	0.8	-	ns	$C_{card} \leq 10$ pF (1 card)
Outputs DAT (referenced to CLK rising and falling edges)					
Output Delay time during Data Transfer Mode	t_{ODLY2x}	-	7.0	ns	$C_L \leq 25$ pF (1 card)
Output Hold time	T_{OH2x}	1.5	-	ns	$C_L \geq 15$ pF (1 card)

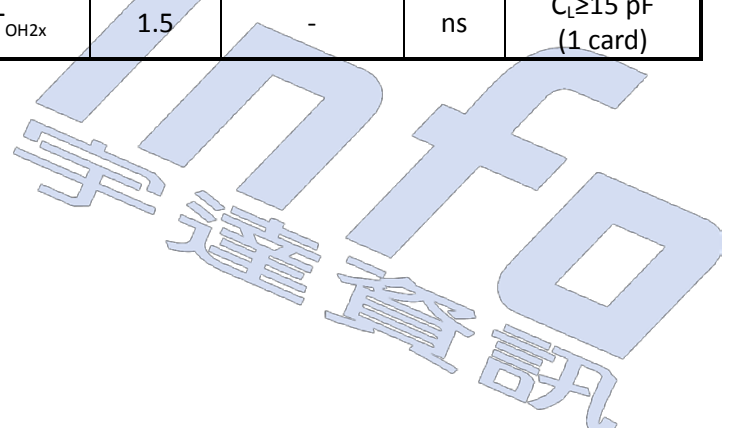

6. INTERFACE

6.1. Pad Assignment and Descriptions

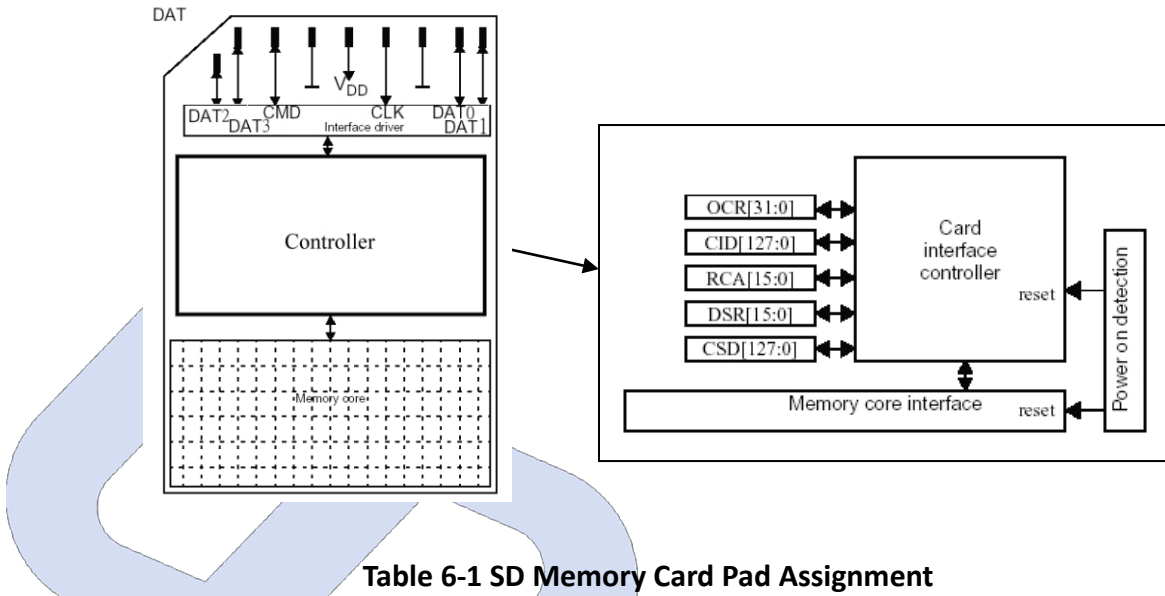

Table 6-1 SD Memory Card Pad Assignment

pin	SD Mode			SPI Mode		
	Name	Type ¹	Description	Name	Type	Description
1	CD/DAT3 ²	I/O/PP ³	Card Detect/ Data Line[bit3]	CS	I ³	Chip Select (net true)
2	CMD	PP	Command/Response	DI	I	Data In
3	V _{SS1}	S	Supply voltage ground	VSS	S	Supply voltage ground
4	V _{DD}	S	Supply voltage	VDD	S	Supply voltage
5	CLK	I	Clock	SCLK	I	Clock
6	V _{SS2}	S	Supply voltage ground	VSS2	S	Supply voltage ground
7	DAT0	I/O/PP	Data Line[bit0]	DO	O/PP	Data Out
8	DAT1	I/O/PP	Data Line[bit1]	RSV		
9	DAT2	I/O/PP	Data Line[bit2]	RSV		

- (1) S: power supply, I: input; O: output using push-pull drivers; PP: I/O using push-pull drivers.
- (2) The extended DAT lines (DAT1-DAT3) are input on power up. They start to operate as DAT lines after SET_BUS_WIDTH command. The Host shall keep its own DAT1-DAT3 lines in input mode as well while they are not used. It is defined so in order to keep compatibility to MultiMedia Cards.
- (3) At power up, this line has a 50Kohm pull up enabled in the card. This resistor serves two functions: Card detection and Mode Selection. For Mode Selection, the host can drive the line high or let it be pulled high to select SD mode. If the host wants to select SPI mode, it should drive the line low. For Card detection, the host detects that the line is pulled high. This pull-up should be disconnected by the user during regular data transfer with SET_CLR_CARD_DETECT (ACMD42) command.

Name	Width	Description
CID	128bit	Card identification number; card individual number for identification. Mandatory
RCA1	16bit	Relative card address; local system address of a card, dynamically suggested by the card and approved by the host during initialization. Mandatory
DSR	16bit	Driver Stage Register; to configure the card's output drivers. Optional
CSD	128bit	Card Specific Data; information about the card operation conditions. Mandatory
SCR	64bit	SD Configuration Register; information about the SD Memory Card's Special Features capabilities Mandatory
OCR	32bit	Operation conditions register. Mandatory.
SSR	512bit	SD Status; information about the card proprietary features Mandatory
OCR	32bit	Card Status; information about the card status Mandatory

(1) RCA register is not used (or available) in SPI mode.

7. PHYSICAL DIMENSION



Dimension: 32mm(L) x 24mm(W) x 2.1mm(H)

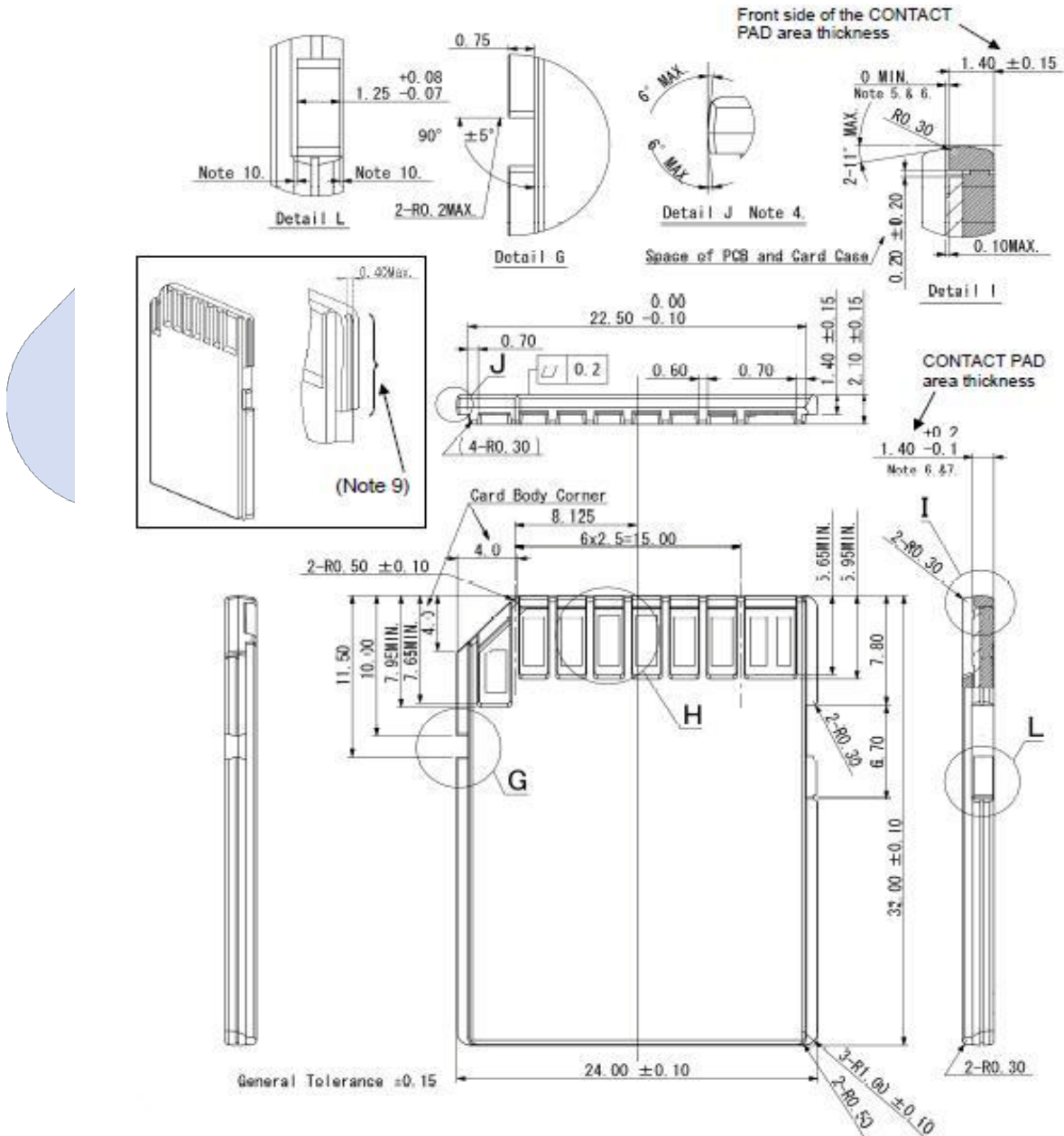

UD info CORP. TEL: +886-2-7713-6050 FAX: +86-2-8511-3151

3F-4, No.8, Ln. 609, Sec. 5, Chongxin Rd., Sanchong Dist., New Taipei City 241, Taiwan (R.O.C.)

8. BARCODE DESCRIPTION

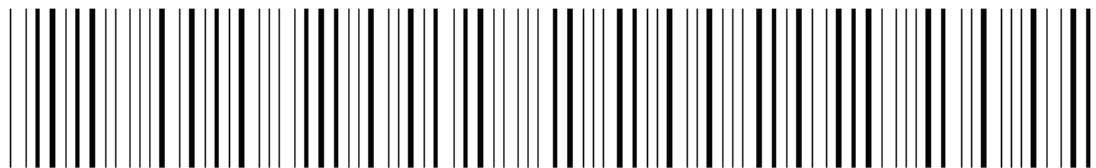

S D C 0 9 U D 0 6 4 G B C S P

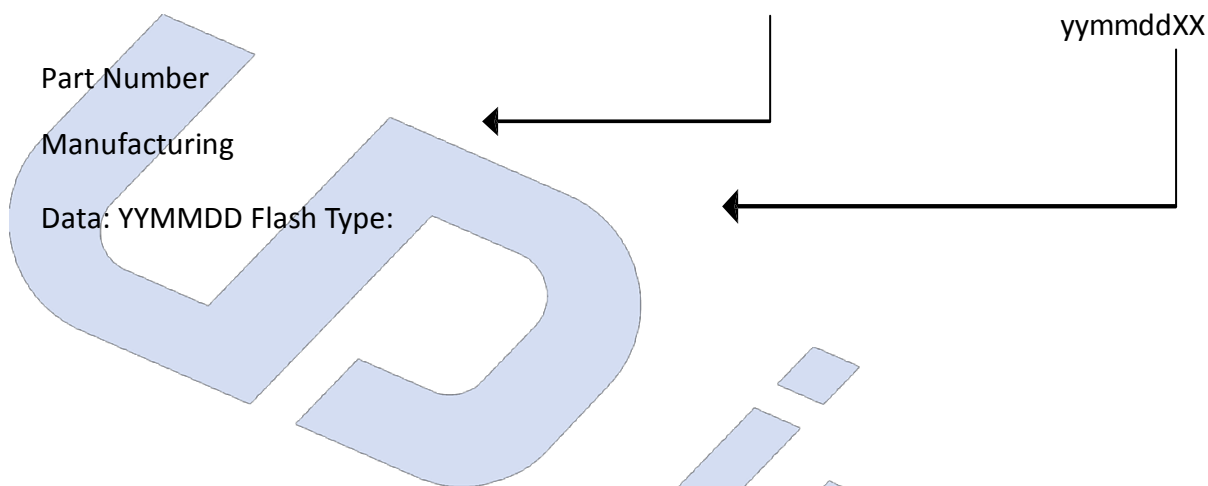

9. PARTNUMBER DECODER

SDC-09UDX⁸X⁹X¹⁰X¹¹X¹² X¹³ X¹⁴ X¹⁵

X ¹ X ² X ³	X ⁴ X ⁵	X ⁶ X ⁷	X ⁸ X ⁹ X ¹⁰ X ¹¹ X ¹²	X ¹³	X ¹⁴	X ¹⁵
SDC	09	UD	128MB 004GB 256MB 008GB 512MB 016GB 001GB 032GB 002GB 064GB	C: SLC Standard (0°C ~ +70°C) D: SLC Gold (-25°C ~ +85°C) I: SLC Industrial (-40°C ~ +85°C) K: MLC Standard (0°C ~ +70°C) L: MLC Gold (-25°C ~ +85°C) M: MLC Industrial (-40°C ~ +85°C) P: pSLC Standard (0°C ~ +70°C) Q: pSLC Gold (-25°C ~ +85°C) F: pSLC Industrial (-40°C ~ +85°C)	2: Class 2 4: Class 4 6: Class 6 A: Class 10 S: UHS	P